

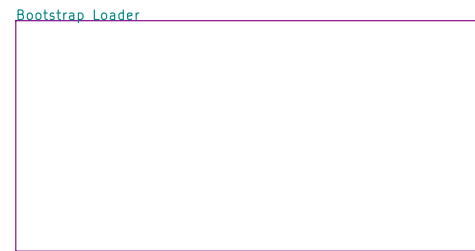

ram.sch



bootstrap-cpld.sch



bootstrap-loader.sch

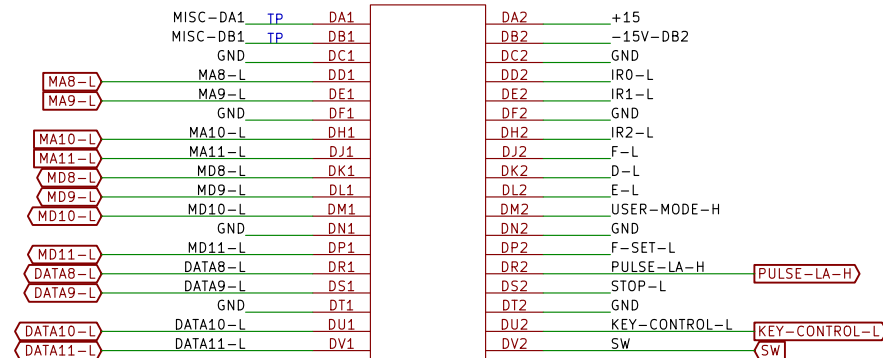
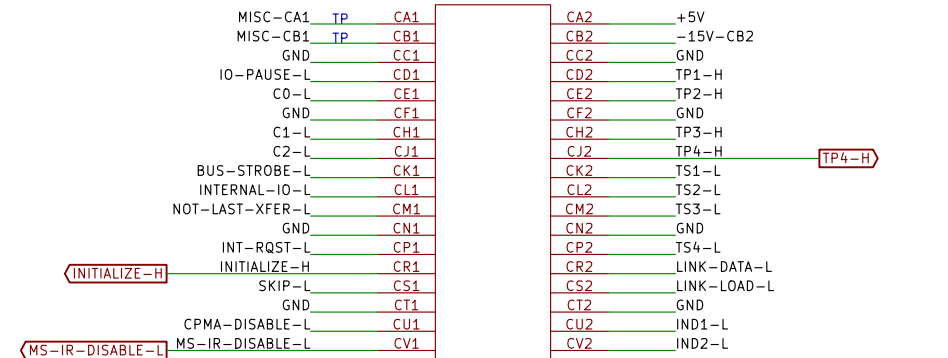
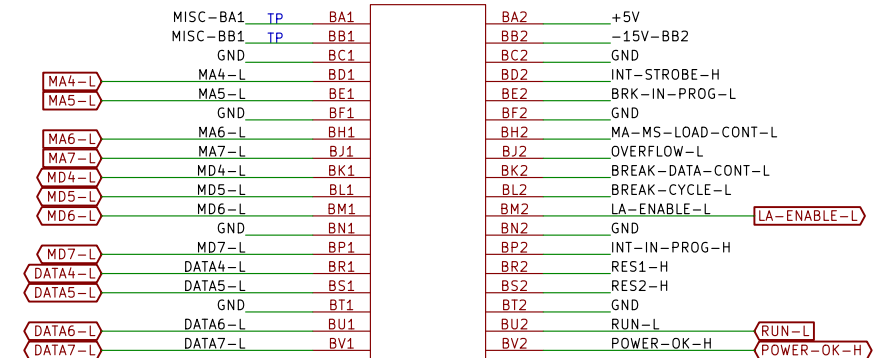
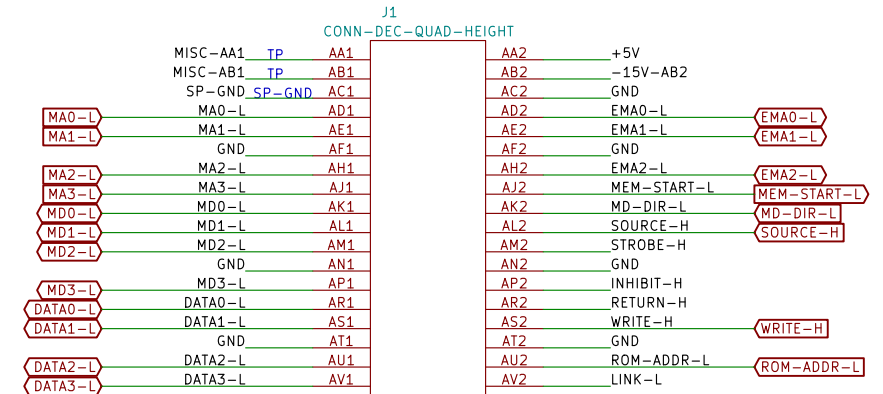
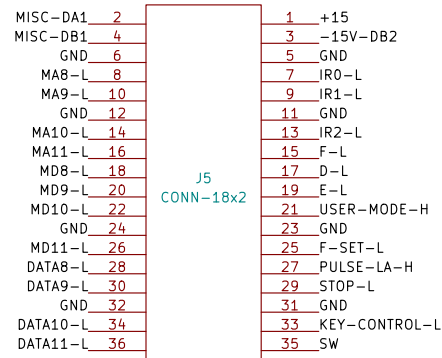
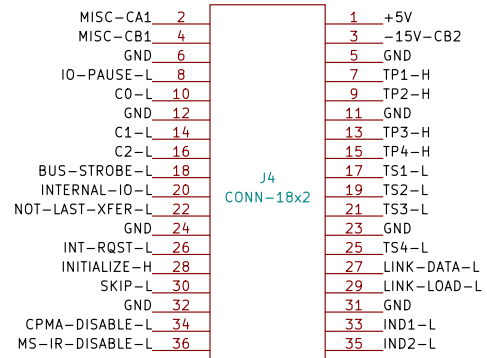
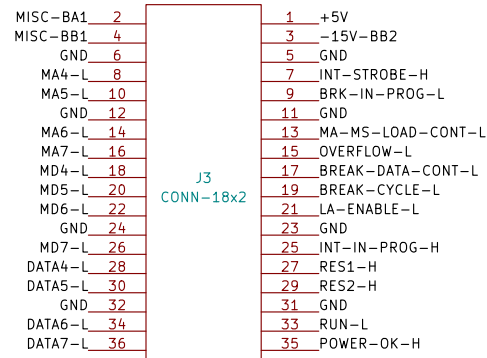
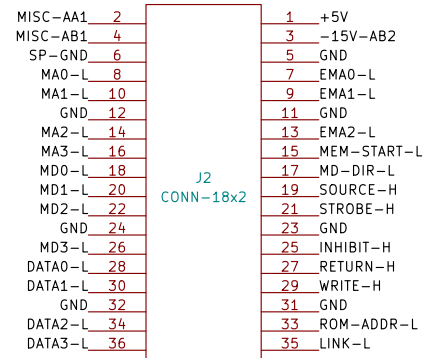
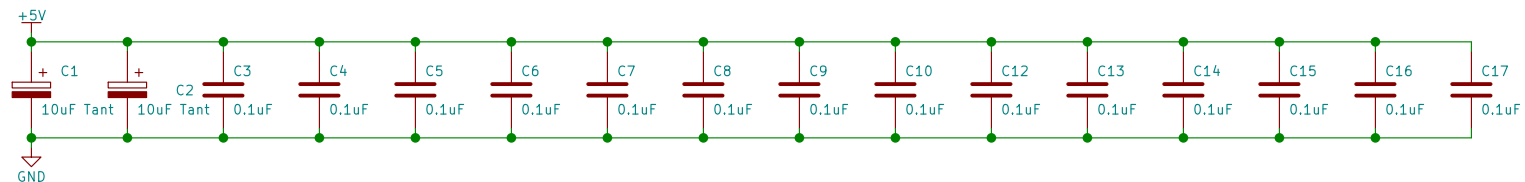
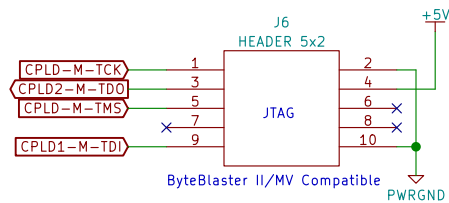
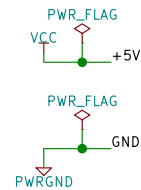
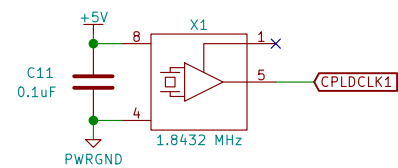

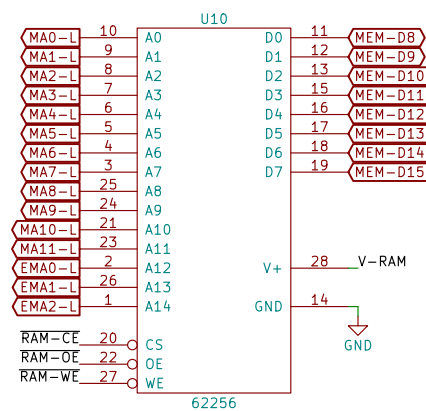
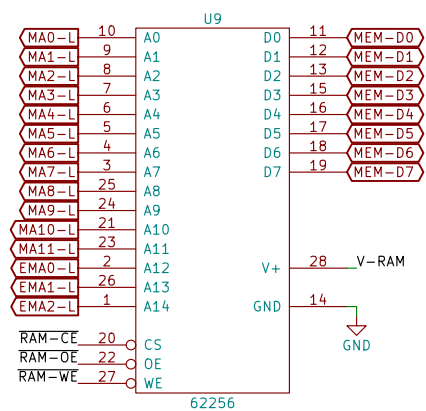
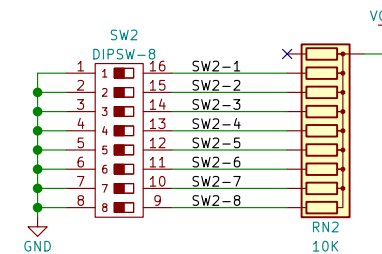
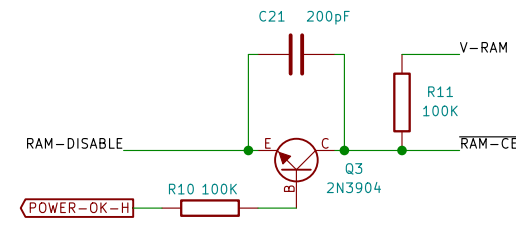
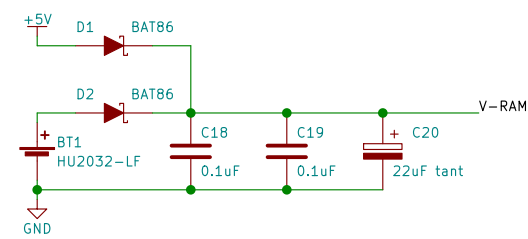
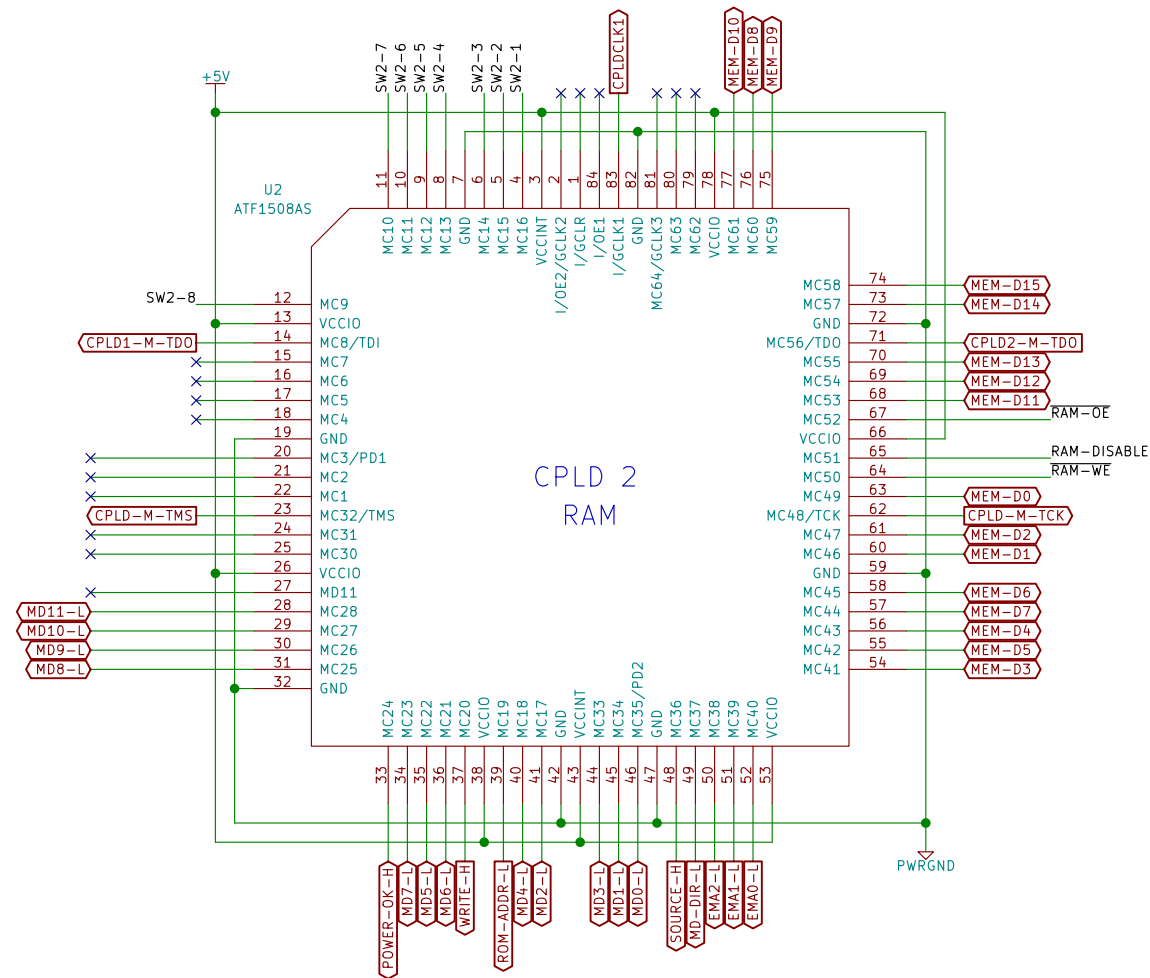

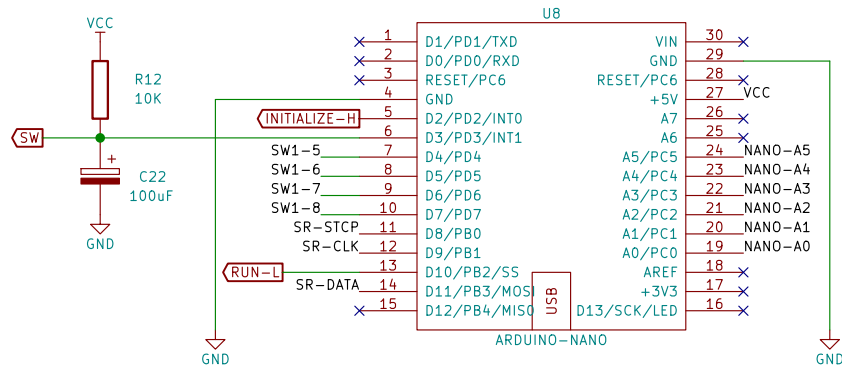
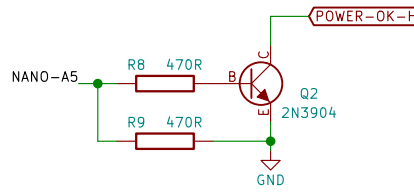
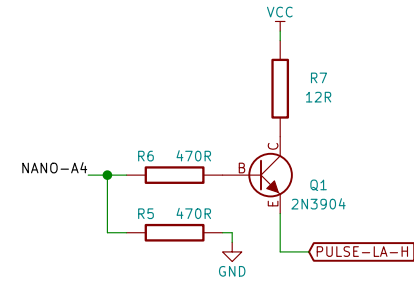
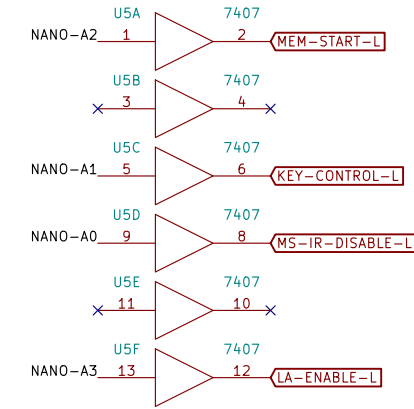
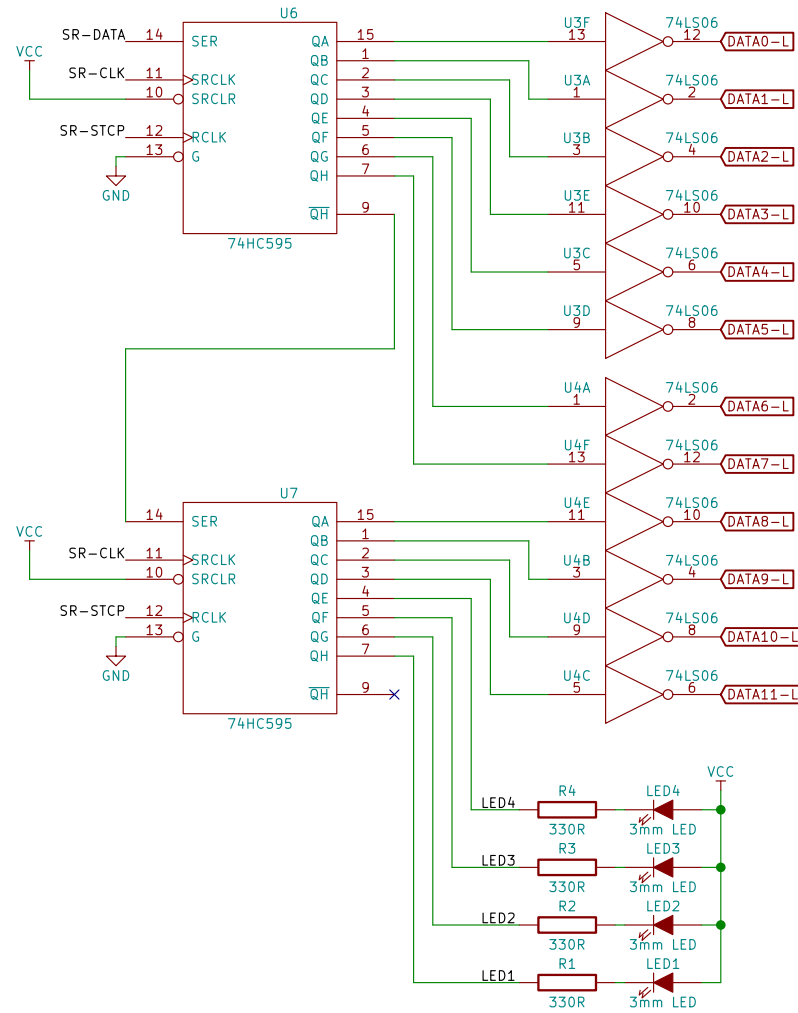
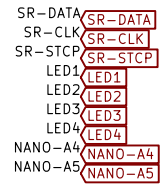
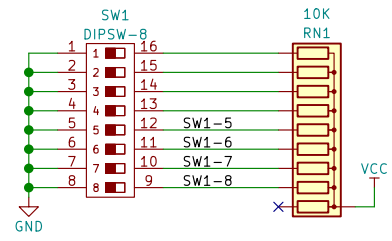

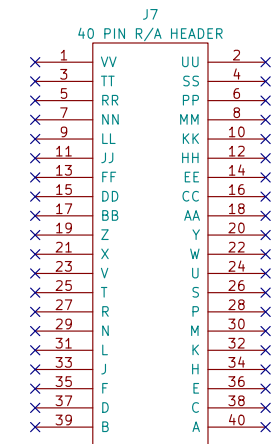
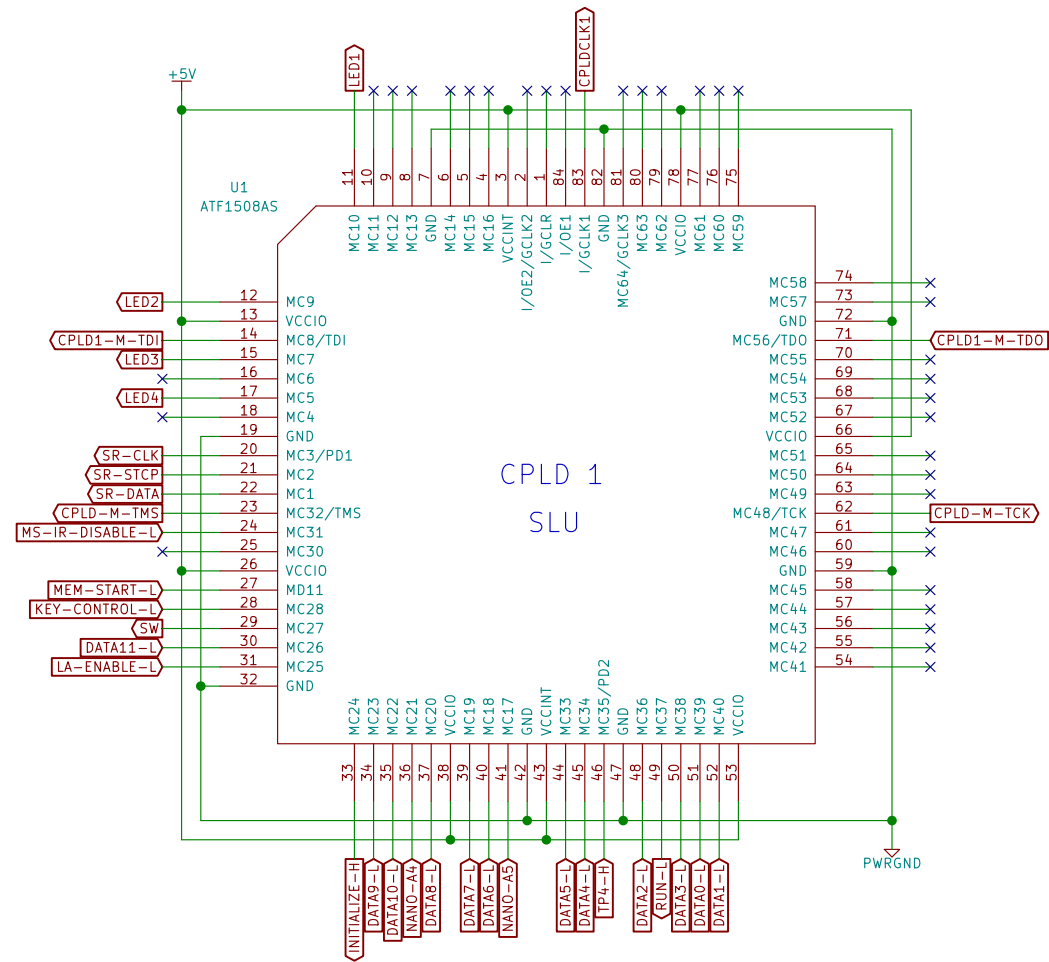

malcolm@avitech.com.au
 Malcolm Macleod
www.avitech.com.au
 Sheet: /Bootstrap CPLD/
 File: bootstrap-cpld.sch

Title: OMNIBUS Prototype: Bootstrap Loader and 32K RAM

Size: A3 Date: 4 August 2018
 KiCad E.D.A. kicad 4.0.6

Rev: v1.0
 Id: 4/4